

APQ GAS REGULATOR INCORPORATE WITH SATEY SHUT-OFF VALVE

Model R 5100 – R 5100S

Rp 2" or DN 50

The main characteristic of the regulators of direct action, with adjusted by wharf of series R 5100 and stopper of compensated effect, it is the stability of the pressure of exit before variations of the inlet pressure and very high tamano a relation of great volume / , offering great gas volumes.

Typical applications are in closets of regulation of plurifamiliares, local property commercial or in the lines of distribution in industrials where they consume gas. .

Natural gas, manufactured gas, propane, butane, biogas, air and other gases can work with that do not have a high content in benzol.

It comes equipped with a device anti-pumping to to slow up and backflow of gas and air in the regulation head. It's in order avoid oscillations.

Technical specifications

Pe. Max :	6 bar
P outlet :	20 - 350 mbar
Cinnection :	
Thread Conn.	2 " BSP female
Flange Conn.	DN 50 PN 16/25
Position Assembly :	Segun fotografia ± 90°
Operating Temperature	-10 to + 50C°

Materials

Regulating body :	Sheroidal Fundic
Body regulation:	Aluminum Casting
Howitzer:	Extruido Brass
Stopper:	Vulcanized Brass
Membranes:	Nitrilicas
Together:	Nitrilicas
Body Blockade:	Aluminate Casting



The ramming intake of regulation, makes it inner, reason why it does not need external taking of impulses.

Safety valve the regulator,

can come equipped with mounted safety shut off valve by maximum in the inferior part of the regulator, Taking the denomination from R 5100/S (BPo MP). The function of the safety valve is to to cut off the gas flow when the regulator outlet pressure does not reach or exceeds the set minimums or maximum pressure valves, reason why either of an external taking of impulses

APQ GAS REGULATOR INCORPORATE WITH SATETY SHUT-OFF VALVE

Model R 5100 - R 5100/S

Rp 2" or DN 50

Code	Articles	Pressure Outlet	Weight
RI. ROC. 5000.BP	Rulator R 5100 BP	20 - 100 mbar	13.7 kg
RI. ROC. 5000.MP	Rulator R 5100 MP	80 - 350 mbar	13.7 kg
RI. ROC. 5010. BP	Rulator R 5100/S BP	20 - 100 mbar	14.2 kg
RI. ROC. 5010. MP	Rulator R 5100/S MP	80 - 350 mbar	14.2 kg
CE.900.4040.D	Flange Adaptor DN50 PN25 with nect connector 2 "		3.8 kg

Dimensions (mm)

Model	Connection	A Ø	B	C	D	E	F	G	I	K Ø	L
R 5100	2"	280	400	600	-	-	156	75	-	10	290
R 5100/S	2"	280	400	600	220	275	156	-	120	10	290

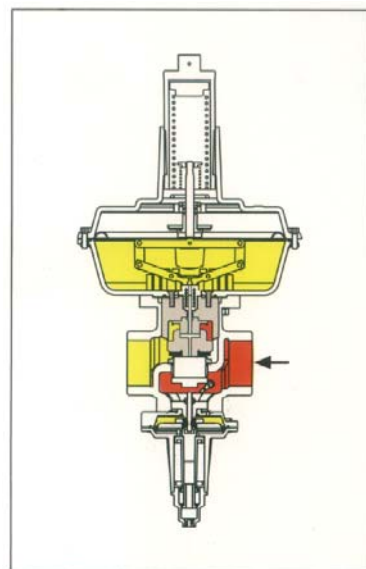
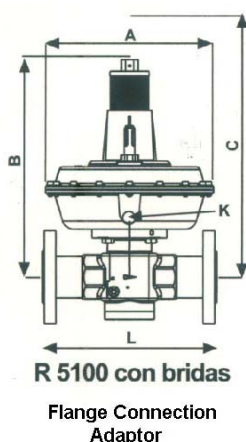
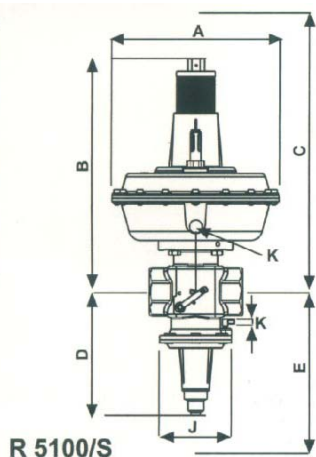
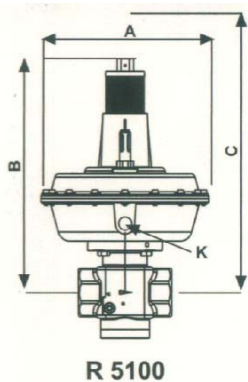

Model R 5100 MP Regulator only and R 5100/S complete with Safety Shut-off Valve.