

UV Detectors

QRA...



ISO 9001



QRA10...



QRA53..., QRA55... with clamp



QRA2... with clamp

Flame detectors for use with Landis & Staefa burner controls, for the supervision of gas flames and oil flames.

The QRA... and this data sheet are intended for use by OEMs that integrate the UV detectors in their products!

Use

The QRA... are used for the supervision of gas flames, yellow- or blue-burning oil flames and for ignition spark proving.

Type reference	For use with burner control type	Operating mode
QRA2..., QRA10...	LFM1..., LGB2/4... ¹⁾ , LFL..., LFE1..., LGI21..., LFE10	Intermittent
QRA53..., QRA55...	LGK16..., LGI16...	Continuous

Legend

1) With AGQ1...

Function

With this type of flame supervision, the UV radiation emitted by gas or oil flames is used to generate the flame signal.

The radiation detector is a UV-sensitive cell with two electrodes, which ignite when illuminated with radiation in the 190...270 nm range of the spectrum, thereby initiating a current in the flame detector circuit.

The UV cell does not respond to glowing firebrick in the combustion chamber, daylight or light from the boiler room illumination.

Halogen lamps, welding equipment or ignition sparks may emit enough UV radiation for the cell to ignite. X-ray and gamma radiation may also generate erroneous flame signals.

Technical data

Average life of UV cell	approx. 10,000 h at +50 °C max., higher ambient temperatures reduce the cell's life considerably!	Mounting position	optional
Permissible combustion chamber pressure	- QRA10... 50 mbar max. - QRA10... + AGG03 or AGG02 500 mbar max.	Weight	- AGG16... 650 g - QRA2... 60 g - QRA10... + AGG03 750 g - QRA53..., QRA55... 900 g
Degree of protection	- QRA2 IP 40 - QRA10... IP 54 - QRA53..., QRA55... IP 54		
Ambient conditions	- Transport IEC721-3-2 class 2K2 Climatic conditions Temperature -20...+60 °C Humidity < 95 % r.h. Mechanical conditions class 2M2		
- Operation	IEC721-3-3 class 3K5 Climatic conditions Temperature -20...+60 °C Humidity < 95 % r.h.		

Condensation, formation of ice and ingress of water are not permitted!

Type summary UV detectors

Type reference	Sensitivity	Flange and clamp	Terminal cover	Spare UV tube
QRA2	normal	without	black	4 502 1131 0
QRA2(1)	normal	with	black	4 502 1131 0
QRA2.9²⁾	normal	without	black	4 502 1131 0
QRA2.9(1)²⁾	normal	with	black	4 502 1131 0
QRA2M	high	without	green	4 502 4065 7
QRA2M(1)	high	with	green	4 502 4065 7
QRA10.C	normal	—	—	4 502 1131 0
QRA10M.C	high	—	—	4 502 4065 7

Type reference	Sensitivity	Detector tube length	Mains voltage	Spare UV tube
QRA53.C27	normal	125 mm	AC 220...240 V	4 502 4065 7
QRA53.C17	normal	125 mm	AC 100...110 V	4 502 4065 7
QRA53.D27	high	125 mm	AC 220...240 V	4 502 4065 7
QRA53.D17	high	125 mm	AC 100...110 V	4 502 4065 7
QRA55.C27	normal	77 mm	AC 220...240 V	4 502 4065 7
QRA55.C17	normal	77 mm	AC 100...110 V	4 502 4065 7
QRA55.D27	high	77 mm	AC 220...240 V	4 502 4065 7
QRA55.D17	high	77 mm	AC 100...110 V	4 502 4065 7

Note

All QRA5... are delivered with clamp.

Use of the detector requires a connecting cable **AGM19** (refer to «Accessories» for QRA5...).

Accessories for QRA2... and QRA5... when ordered as single items

Item	For use with	Part number
Flange ³⁾	QRA2...	4 241 8855 0
Clamp ³⁾	QRA2...	4 199 8806 0
Clamp for direct mounting ⁴⁾	QRA5...	4 199 1034 0

Accessories for QRA5...

Type reference	Description
AGG16.C	Adapter for QRA53... and QRA55...
AGM19	Plug complete with 2 m cable for QRA53... and QRA55...
KF8832	Unit for measuring the detector current with QRA53... and QRA55..., recommended for use with types up to C-series

Accessories for QRA10... and AGG16...

Type reference	Description
AGG02	Heat insulation glass with spring and O-ring
AGG03⁵⁾	Quartz glass lens with spring and O-ring
AGG05	1 in. nipple
AGG06	Glass and quartz glass lens holder with intermediate ring
AGG07	Ball head, internally threaded (1 in.)



AGG16...



KF8832



AGM19...



AGG05...



AGG06... with intermediate ring



AGG07...

Legend

- 2) With heat-resistant casing for short-time (a few seconds) ambient temperature peaks of up to +200 °C
- 3) Supplied with QRA2... (1) types
- 4) Supplied with QRA5... types
- 5) For units of the B-series, lens AGG01 is available

Ordering

When ordering, please give type reference according to «Type summary».

Mechanical design of the detectors

UV detectors QRA2...

Plastic casing, metalized to prevent static charging caused by the air flow from the fan. For direct mounting on the burner. Supplied with or without securing flange and clamp (refer to «Type summary»).

UV detectors QRA10...

Die-cast aluminium casing with a mounting coupling (D) having a 1 in. internal thread and a connection facility for cooling air. The casing of this detector has a bayonet fitting which allows it to be secured either directly to the 1 in. mounting coupling or the AGG06 glass holder. The 1 in. mounting coupling can be screwed to a viewing tube or the AGG07 ball head. The Pg cable gland can be removed and replaced, if some other detector cable is used.

UV detectors QRA5...

The UV cell is located behind a swiveling shutter at the front end of the detector tube that is flanged to the casing. A quartz glass window protects the tube and the shutter against dirt. This UV detector can be mounted either directly on the burner or on a viewing tube or a combustion chamber viewing hole using the adapter AGG16.... The detector's casing accommodates a stepping motor to drive the shutter and the electronics to control the shutter.

Mechanical design of the accessories

Plug AGM19

Plug AGM19 complete with cable for connection of the UV detectors QRA53... and QRA55...

Adapter AGG16...

Adapter AGG16... for use with the QRA53... and QRA55..., made of die-cast aluminium with a 1 in. mounting coupling. The 1 in. mounting coupling type (D) is attached to the casing using a bayonet fitting.

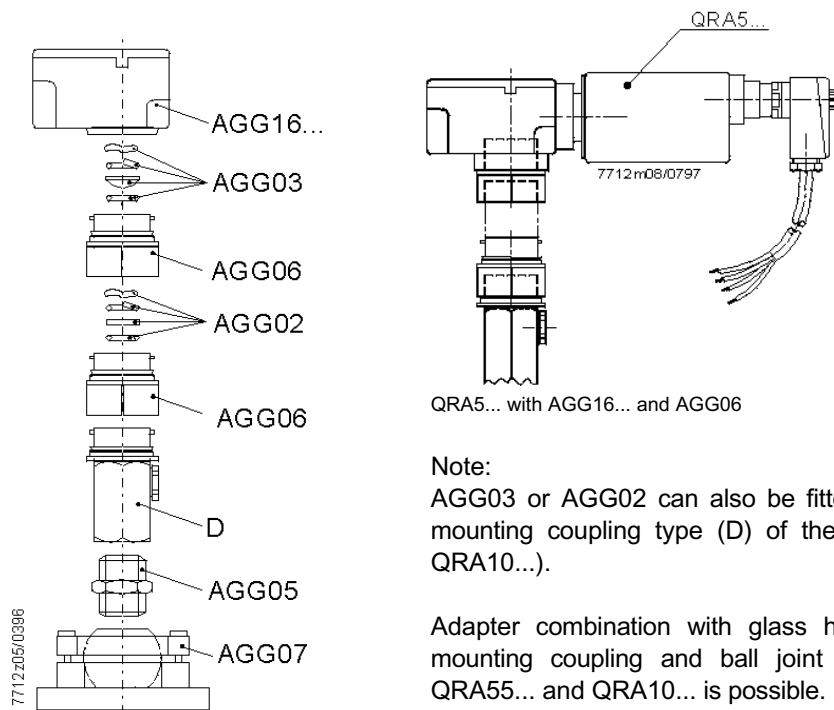

Glass and quartz glass lens holder AGG06

The glass and quartz glass lens holder AGG06 serves for holding the lens AGG03 and the heat insulation glass AGG02. The lens is used to increase the sensitivity, and the heat insulation glass provides protection against high temperatures, thus extending the life of the UV cell.

The AGG06 also allows various combinations of lens, heat insulation glass and 1 in. mounting coupling to be made.

When using the lens and the heat insulation glass, the AGG06 with the lens must be mounted as close as possible to the UV detector.

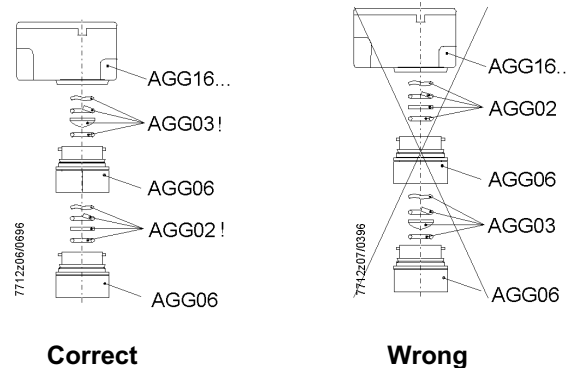

AGG06 has a bayonet fitting by means of which it is attached either to the casing of the adapter AGG16... or the casing of the detector QRA10... and the 1 in. mounting coupling. By undoing the bayonet fittings on both sides, the AGG06 glass holder(s) can be easily detached from the respective combination of QRA10... or AGG16... and QRA53..., QRA55....

This facilitates straightforward cleaning of the glass or lens without removing them from the glass holder AGG06.

The intermediate rings are used for the smooth running of the bayonet fittings. They are used especially where, after removal of the UV detector, the hole to the combustion chamber is used as a viewing tube. By fitting the intermediate ring to the appropriate bayonet connection, the combination can be undone where required by rotating the casing of QRA10... or AGG16....

Quartz glass lens AGG03

AGG03 with spring washer and O-ring for increasing the sensitivity.

Heat insulation glass AGG02

Heat insulation glass AGG02 with spring washer and O-ring, same mounting choices as with the AGG03.

This heat insulation glass is required where the temperature at the UV cell would exceed 80 °C.

Mounting coupling (D)

Using the bayonet fitting, the 1 in. mounting coupling can be attached either to the AGG06, the AGG16... or the UV detector QRA10....

Supplied with QRA10... or AGG16...

Nipple AGG05

1 in. nipple AGG05 for connecting the 1 in. mounting coupling (D) to the ball head AGG07.

Ball head AGG07

Ball head AGG07 with a 1 in. internal thread. For use with the 1 in. mounting coupling and AGG06. The AGG07 is used for mounting on a rigid surface, such as the boiler wall. It facilitates optimum adjustment of the viewing angle.

Commissioning notes

Trouble-free burner operation is ensured only when the intensity of UV radiation at the detector's location is so high that the UV cell ignites during each half wave. The **intensity of UV radiation at the detector's location** is checked through **measurement of the detector current**.

Measuring circuit for QRA2..., QRA10... and QRA5... D-series

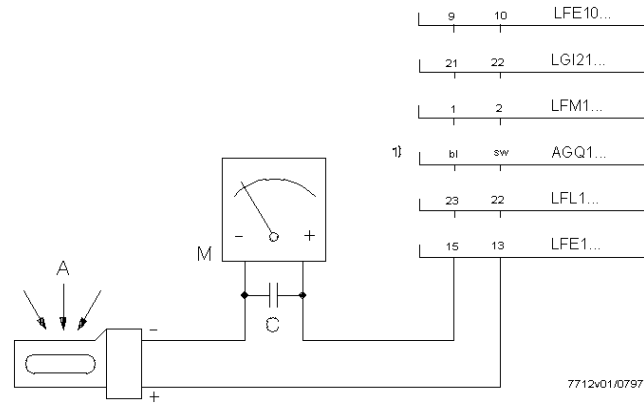

Legend

- 1) Connection of microammeter across adapter AGQ1... and UV cell
 A Incidence of radiation
 M Microammeter (DC), internal resistance $\leq 5000 \Omega$
 C Electrolytic capacitor 100...470 μF , DC 10...25 V

Measuring circuit for QRA5... up to C-series

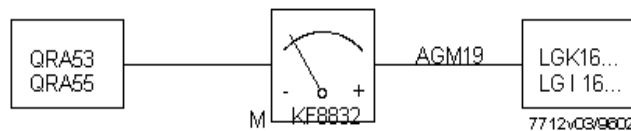

Required minimum detector current values:

Refer to the data sheets of the respective burner controls or to the operating instructions of KF8832.

Warning notes

- In the geographical areas where DIN standards are in use, the installation must be in compliance with VDE requirements, particularly with the standards DIN / VDE 0100 and 0722!
- All regulations and standards applicable to the particular application must be observed!
- Installation and commissioning work must always be carried out by qualified personnel!
- Condensation and ingress of humidity must be avoided!
- The electrical wiring must be made in compliance with national and local standards and regulations!
- Ignition cables must always be laid separately, maintaining the greatest possible distance to the QRA... and other cables!
- QRA... are safety devices. It is therefore not permitted to open, interfere with or modify the detectors!
- Check wiring carefully before putting the detector into operation!
- Check all safety functions when putting the detector into operation or after performing service work!
- Electromagnetic emissions must be checked from an application point of view!

Dimensions

Dimensions in mm

QRA2...

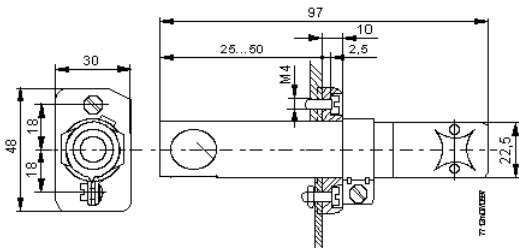

QRA10...

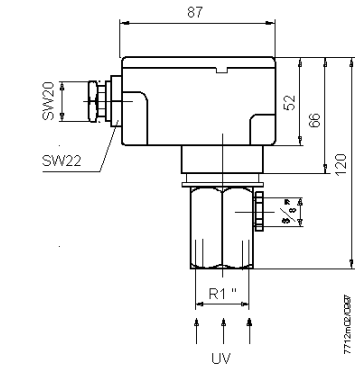

AGG02

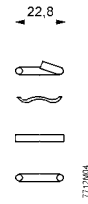

AGG03

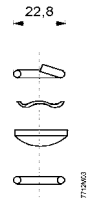

QRA5...

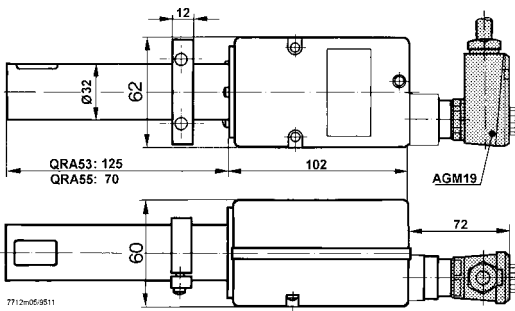

QRA5... with AGG16..., ...06, ...05, ...07 and AGM19

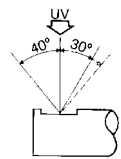
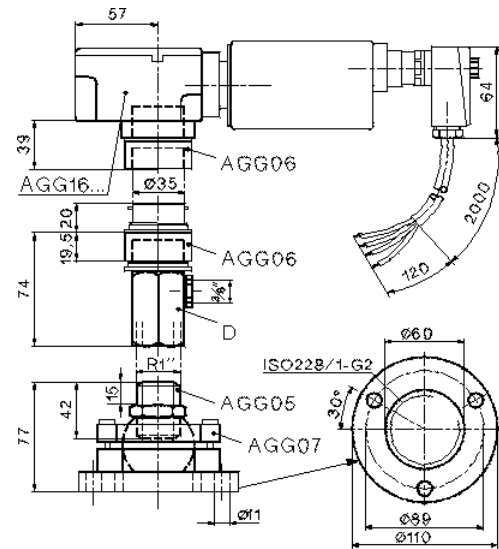

Incidence of radiation

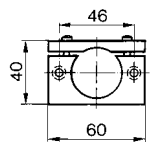

Clamp for direct mounting on the burner or the AGG16...

